

## ALTAVOZ EXPONENCIAL IP67

**AEI-12T**

**12 W**

**112 dB**

Altavoz exponencial con elevado grado de protección (IP67), para funcionar en condiciones climáticas extremas, adecuado para entornos industriales y marinos.

Potencia RMS	12 W
Selección de potencia	12, 6, 3 y 1 W
Conexión baja impedancia	8 ohm
Respuesta en frecuencia	510 ~ 12.000 Hz
SPL 1 m, 1 kHz	98 dB (1 W) / 109 dB (12 W)
Temperatura de trabajo	-30° C a 70° C
Grado de protección	IP67 (IEC-529)
Acabado	HIPS RAL 7035
Dimensiones (mm)	110 (largo), 143 (boca)
Peso	1,0 kg



### Montaje

### Dimensiones

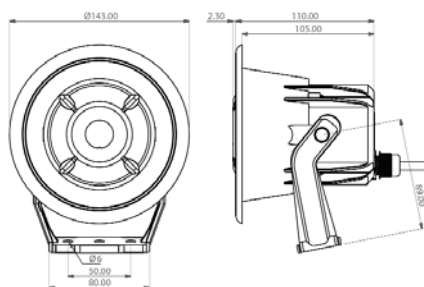
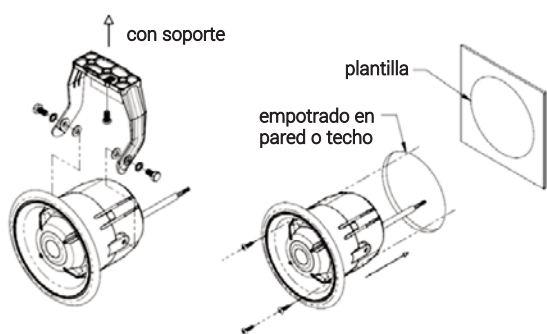

AEI12T\_ES

C/ Barcelona 101  
17003 Girona (Spain)  
(+34) 972 203 300

**OPTIMUS**  
SOUND & COMMUNICATION

## IP67 EXPONENTIAL LOUDSPEAKER

**AEI-12T**

**12 W**

**112 dB**

Exponential loudspeaker with a high degree of protection (IP67) to work in extreme weather conditions. Suitable for industrial and maritime environments.

RMS power	12 W
Power selection	12, 6, 3 and 1 W
Low impedance connection	8 Ohm
Frequency response	510 ~ 12,000 Hz
SPL 1 m, 1 kHz	98 dB (1 W)/109 dB (12 W)
Working temperature	-30°C to 70°C
Protection	IP67 (IEC-529)
Finish	HIPS RAL 7035
Dimensions (mm)	110 (long), 143 (mouth)
Weight	1.0 Kg



**IP67**

### Mounting

### Dimensions

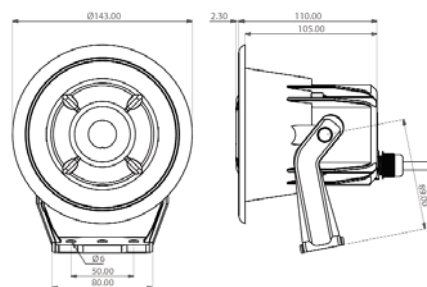
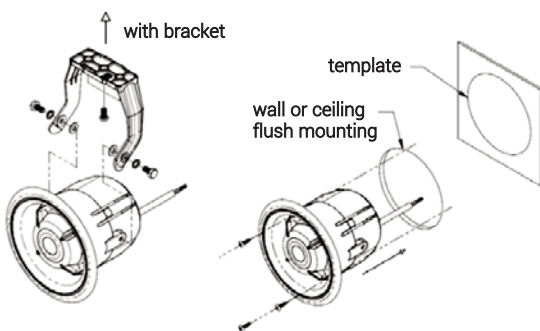

AEI12T\_EN

C/ Barcelona 101  
17003 Girona (Spain)  
(+34) 972 203 300

**OPTIMUS**  
SOUND & COMMUNICATION